

Jiangmen Jeeseng Energy Co., Ltd.

High Voltage Stacking Series User

Manual



---A Safer and More Reliable Green Energy System Service Provider---

Table of Contents

HIGH VOLTAGE STACKING SERIES USER MANUAL	1
1. PREFACE.....	1
1.1 TERMINOLOGY DEFINITIONS	1
1.2 APPLICABLE SCENARIOS	1
2. SAFETY PRECAUTIONS.....	2
3. PRODUCT INTRODUCTION.....	2
4. EQUIPMENT INSPECTION AND STORAGE.....	3
5. SYSTEM INSTALLATION.....	4
6. ELECTRICAL CONNECTIONS.....	7
7. STARTUP AND SHUTDOWN OPERATING PROCEDURE.....	14
8. ROUTINE MAINTENANCE.....	19
9. FAULT DESCRIPTION AND TROUBLESHOOTING.....	19

1. Preface

1.1 Terminology Definitions

DANGER	Indicates a high-level risk hazard that will result in death or serious injury if not avoided.
WARNING	Indicates a medium-level risk hazard that may result in death or serious injury if not avoided.
CAUTION	Indicates a low-level risk hazard that may result in minor or moderate injury if not avoided.
NOTICE	Used to convey equipment or environment safety warning information. If not avoided, it may result in equipment damage, data loss, performance degradation, or other unpredictable consequences. "NOTICE" does not involve personal injury.
Description	Supplementary explanation of key information in the text. "Description" is not a safety warning and does not involve personal, equipment, or environment injury information.
Professional Personnel	Personnel with training or equipment operation experience who can clearly understand various hazard sources and levels during equipment installation, operation, and maintenance.
Trained Personnel	Personnel who have undergone corresponding technical training and have necessary experience, can recognize the hazards that may be brought by certain operations, and can take measures to minimize the danger to themselves or others.
Operators	Operators other than trained personnel and professional personnel who may come into contact with the equipment.

1.2 Applicable Scenarios

The system can be used for off-grid and grid-tied systems, suitable for various application scenarios such as home users, small agriculture, small business, and electric vehicle charging.

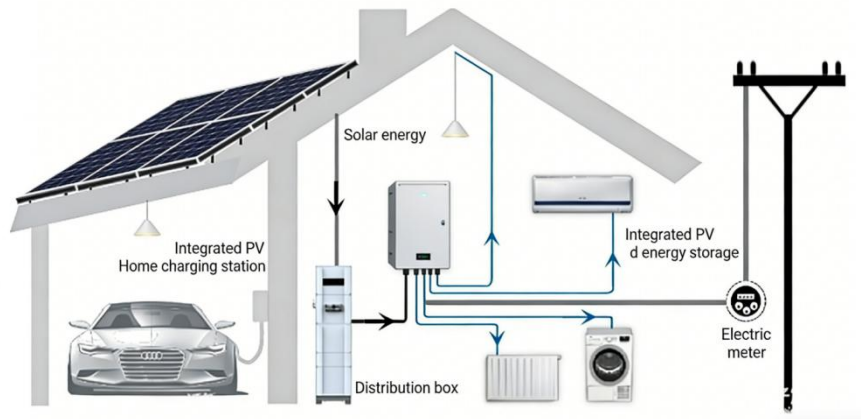

2. Safety Precautions

2.1 General Safety

Before performing electrical connections, ensure the equipment is undamaged, otherwise electric shock or fire may occur, User-provided cables must comply with local laws and regulations, Use specialized insulated tools when performing high-voltage operations.

2.2 Battery Safety

2.2.1 Do not disassemble battery cells under any circumstances.

2.2.2 Do not heat the battery or throw it into fire.

2.2.3 Do not use or place near fire or in very hot environments.

2.2.4 Do not store the battery in humid environments.

2.3 Emergency Measures

2.3.1 Immediately cut off the battery system power to prevent fault escalation and greater losses.

2.3.2 Immediately evacuate office or household members to a safe area.

2.3.3 Immediately call emergency personnel to the scene, investigate and analyze the site, identify the cause of the fault, and develop targeted emergency measures;

3. Product Introduction

3.1 Product Introduction

All-in-one product consists of energy storage battery modules, high-voltage control box, which can be configured into five types of energy storage charging and discharging systems according to user requirements, Can be paired with an inverter to convert DC power from PV and

batteries into AC power for load supply. The system is equipped with EMS (Energy Management System) and BMS (Battery Management System) to achieve data monitoring, early warning, and control.



3.2 Dimensions and Weight

Model	Net Weight (kg)	Dimensions (mm)	Gross Weight (kg)
JEEDDMK512100-1	59.7	600*491.5*210.4	64.21
JEEDDMK512100-2	54.3	600*491.5*196	57.74
JSDD-100A	20	600*491.5*159	90
JEEDD-358100	470.8	600.1x491.5x1411	500.65
JEEDD-307100	416.5	600.1x491.5x1234	442.91
JEEDD-256100	362.2	600.1x491.5x1057	385.17
JEEDD-204100	307.9	600.1x491.5x880	327.43
JEEDD-153100	253.6	600.1x491.5x703	269.69
JEEDD-102100	199.3	600.1x491.5x526	211.95

4. Equipment Inspection and Storage

4.1 Pre-delivery Inspection



4.1.1 Check whether the package exterior is intact and undamaged;

4.1.2 Sign the delivery receipt;

4.1.3 Open the package for inspection. Reject delivery if the package is damaged or incorrect;

4.1.4 After confirmation, return the delivery receipt to the courier. Delivery complete

4.2 Equipment Storage

4.2.1 The equipment storage area temperature should be controlled at $25 \pm 3^\circ \text{C}$, with humidity controlled at 40–80%.

5. System Installation

5.1 INSTALLATION REQUIREMENTS

5.1.1 Ensure the equipment installation environment is well-ventilated.

5.1.2 Do not block ventilation openings or the cooling system during equipment operation to prevent high-temperature fires.

5.1.3 Do not place the equipment in environments with flammable, explosive gases or smoke. Do not perform any operations in such environments.

5.1.4 Do not place the equipment in high salt spray environments.

5.1.5 The load-bearing capacity of the installation floor must be greater than the load generated by the product weight.

5.1.6 Areas where the annual temperature is below 0°C or above 50°C .

5.1.7 Air relative humidity less than 95%.

5.2 BATTERY SYSTEM INSTALLATION

5.2.1 EQUIPMENT HANDLING

Equipment handling requires professional lifting and transportation equipment. The equipment must be protected during handling to prevent product damage.

5.2.2 BATTERY SYSTEM INSTALLATION

5.2.2.1 During equipment installation, as shown in the figure below, the first layer is assembled with JEEDMK512100-1, the second to fourth (up to seventh) layers are assembled with JEEDMK512100-2 product components (order not important), and the top layer is assembled with the high-voltage box JSDD-100A.

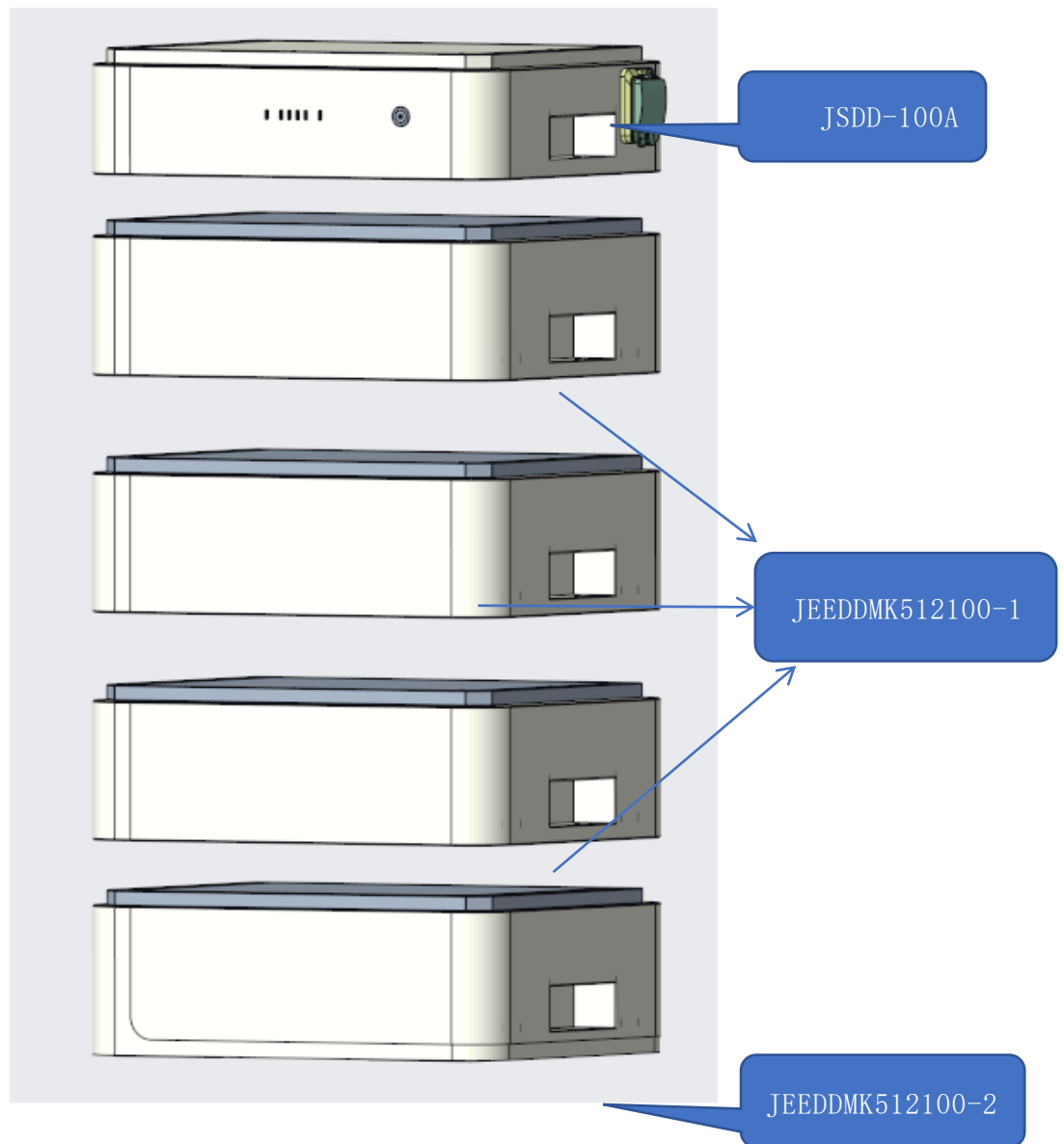

5.2.2.2 Installation Environment Requirements

When selecting the installation location for the battery and supporting inverter equipment,

you must strictly comply with the following environmental standards and installation clearance requirements:

1. Basic Environmental Requirements.

The equipment shall not be installed in areas exposed to direct sunlight. Direct exposure to sunlight will cause equipment overheating, which will lead to output power degradation, component service life attenuation, and in severe cases, trigger the equipment's overheat protection shutdown. It is recommended to install the equipment in a sheltered space free from direct sunlight.

The ideal ambient temperature for normal equipment operation shall not exceed 40°C. For long-term operation, ensure the ambient temperature stays within the rated operating temperature range specified for the equipment, and avoid long-term exposure to extreme environments such as high or low temperatures.

The equipment must be kept away from harsh installation environments including direct sunlight, rain, snow accumulation, condensation, and strong wind-blown sand. Priority shall be given to a ventilated, dry indoor installation location with fixed shelter. The installation location shall be far away from flammable and explosive materials, strong electromagnetic interference sources, and corrosive gases/liquids. Meanwhile, it must be ensured that the ground is solid and flat, and can bear the weight and vibration of the equipment during full-load operation.

2. Minimum Installation Clearance Requirements

To ensure normal ventilation and heat dissipation, daily maintenance access, and operational safety of the equipment, the minimum clearance between the equipment and surrounding obstacles during installation must meet the following requirements (see the figure below for detailed installation clearance requirements):

Minimum horizontal clearance between the left side of the equipment and the wall/surrounding obstacles: $\geq 50\text{cm}$

Minimum horizontal clearance between the right side of the equipment and the wall/surrounding obstacles: $\geq 50\text{cm}$

Minimum ventilation clearance between the back of the equipment and the rear wall/obstacles: $\geq 30\text{cm}$

Minimum vertical clearance between the top of the equipment and the roof/upper obstacles:
 $\geq 50\text{cm}$

(Figure note: The figure below is a schematic diagram of the horizontal installation clearance of the equipment, marking that a minimum safety clearance of no less than 50cm shall be reserved on the left and right sides of the equipment.)

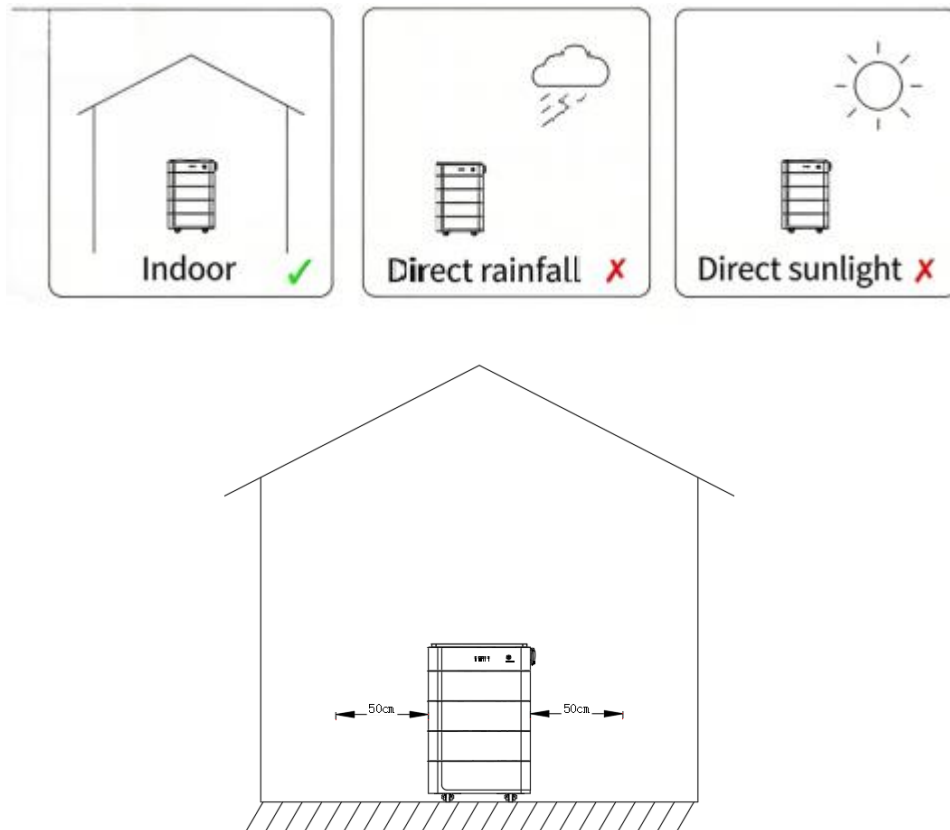

6. Electrical Connections

6.1 SAFETY PRECAUTIONS

6.1.1 Personnel responsible for installing and maintaining the product must first undergo rigorous training, understand various safety precautions, and master correct operating methods.

6.1.2 Only qualified professional personnel or trained personnel are allowed to install, operate, and maintain the equipment.

6.1.3 Only qualified professional personnel are allowed to remove safety facilities and inspect equipment.

6.1.4 Personnel operating the equipment, including operators, trained personnel, and professional personnel, should have special operation qualifications required by the local country, such as high-voltage operation, working at heights, special equipment operation qualifications, etc.

6.1.5 Replacement of equipment or components (including software) must be completed by professional or authorized personnel.



Screw Driver



Crimping Modular



Safety Shoes



Multimeter



Safety Gloves



Safety Goggles



Plier



Ribbon

6.2 INTERFACE DESCRIPTION

6.2.1 High Voltage Box Interface Description

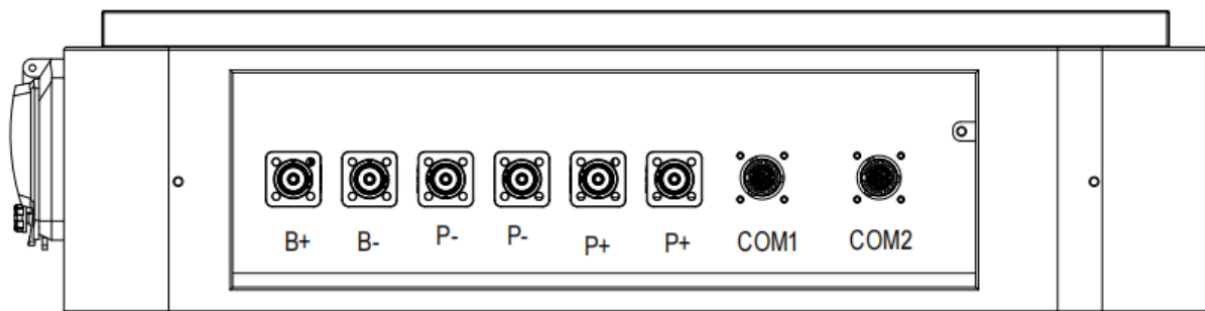

B+	B-	P-	P+	COM1	COM2	
Battery	Battery	Battery	Battery	Communication	Debug Port	Ground
Input Total	Input Total	Output	Output	Connection		Wire

Positive	Negative	Total Negative	Total Positive	Port		Interface
----------	----------	-------------------	-------------------	------	--	-----------

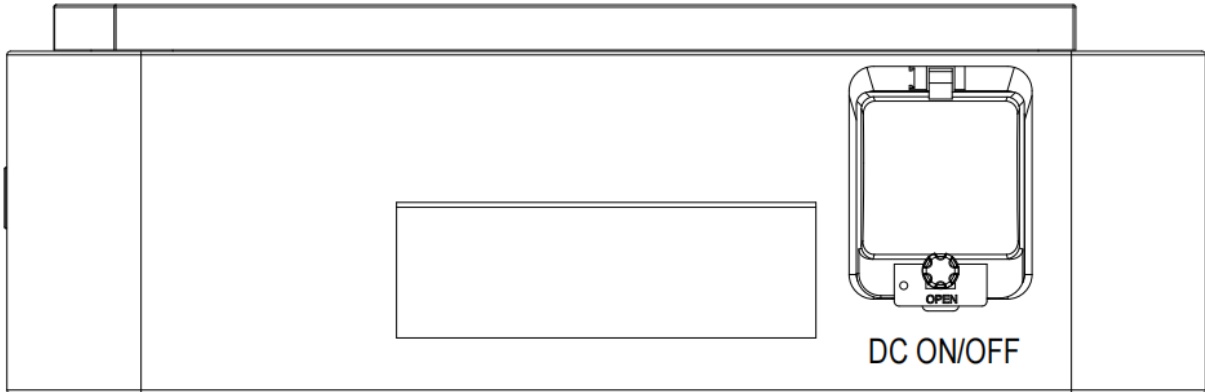

DC ON/OFF
Battery PACK Total Switch

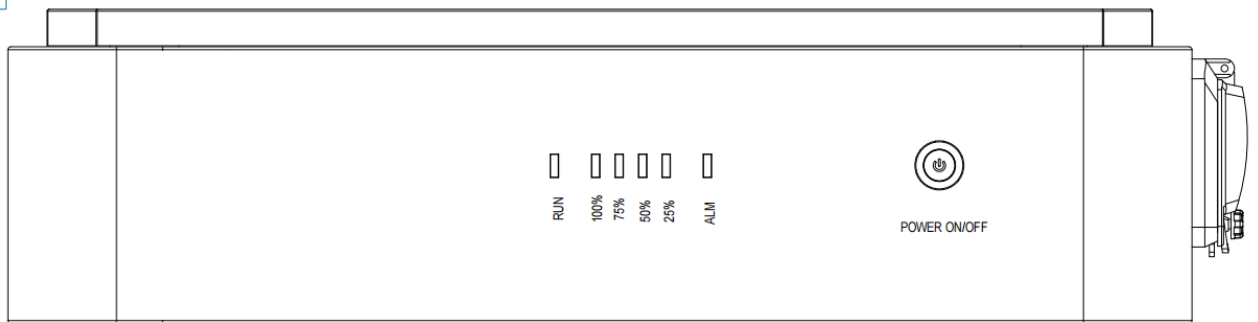

RUN	100%	75%	50%	25%	ALM	POWER ON/OFF
Normal Operation Indicator	Battery Level Indicator	Battery Level Indicator	Battery Level Indicator	Battery Level Indicator	Abnormal Operation Alarm Light	System Switch

6.2.2 Battery Module Interface Description

6.2.2.1 JEEDDMK512100-2 Module Interface Description.

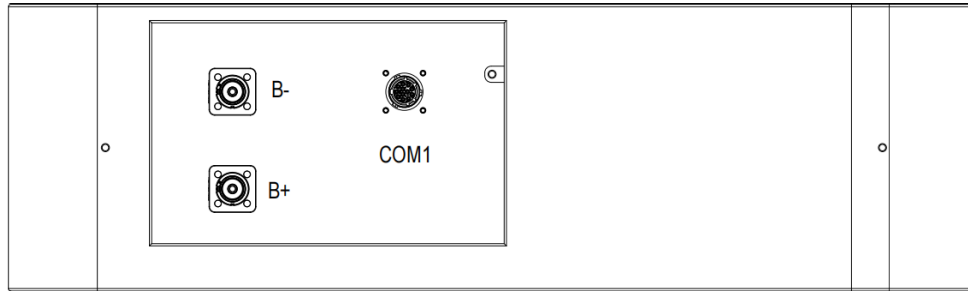

B-	B+	COM1	
Battery Module Output Negative	Battery Module Output Positive	Battery Module Communication Port	Ground Wire Interface

6.2.2.2 JEEDDMK512100-1 Module Interface Description.

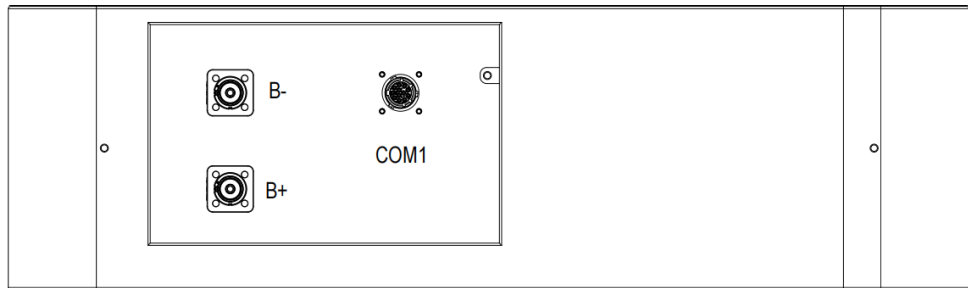

B-	B+	COM1	
Battery Module Output Negative	Battery Module Output Positive	Battery Module Communication Port	Ground Wire Interface

6.3 CONNECTING PROTECTIVE GROUND WIRE

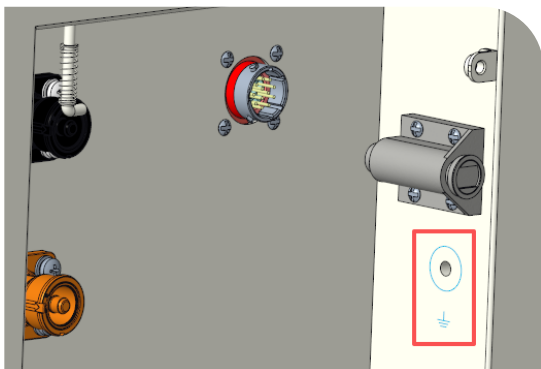

Ground wire installation location between each PACK: Starting from PACK-2, use M4*12 triple combination screws to sequentially lock the ground wire into the PACK (Torque: 2 N·m)

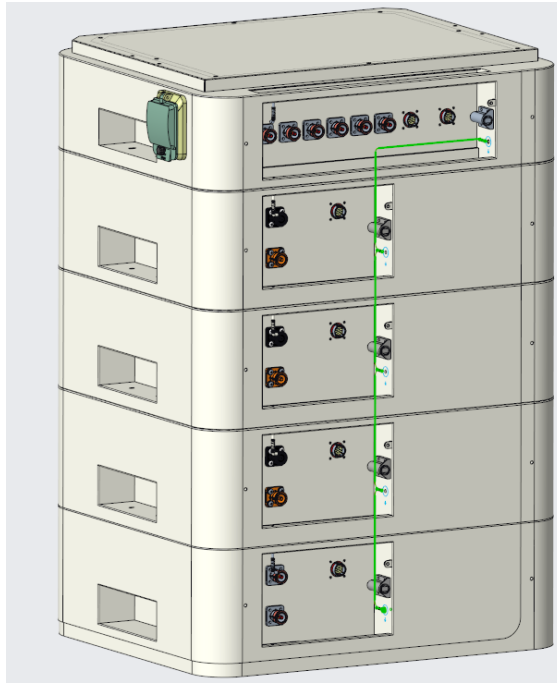

Ground Wire Connection Diagram

No.	Name	Specification	Illustration	Quantity
1	Communication Connection Cable	4 sq mm ground wire, SC4-4 terminals (specific terminal quantity depends on capacity)		1

6.4 ELECTRICAL WIRING CONNECTION

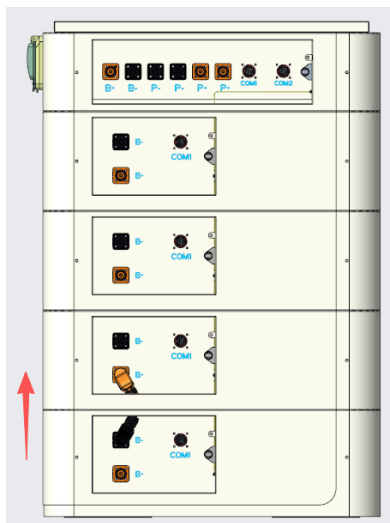

(1)

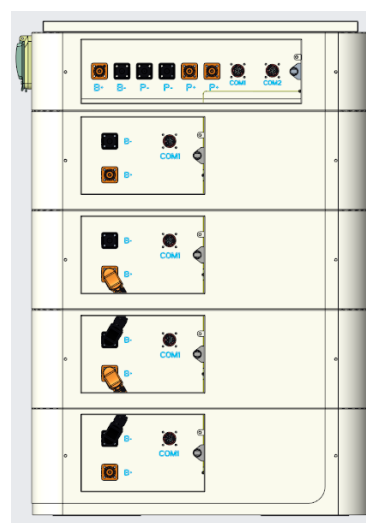

(2)

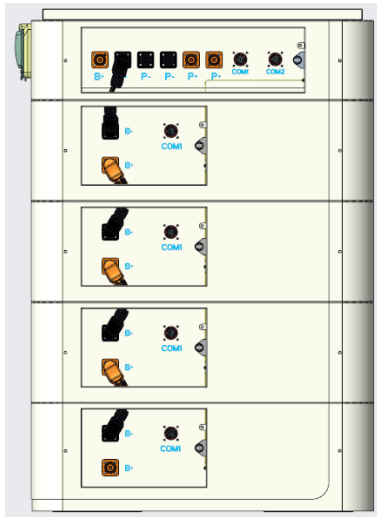

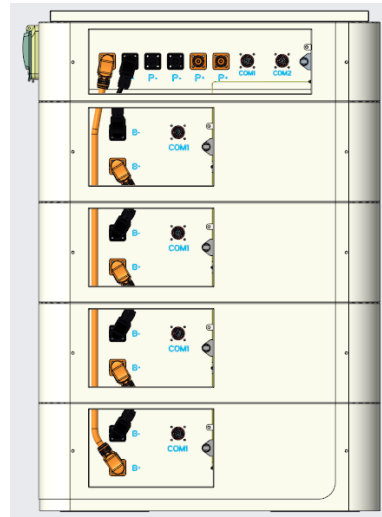

(3)



(4)

Install power cables sequentially starting from PACK-2 according to the diagram. Pay attention to the sound when inserting; a "click" sound indicates proper insertion

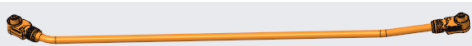
No.	Name	Specification	Illustration	Quantity
1	Total Negative Power Cable	Dual-head black quick connector, rated current: 125A		1
2	Cascade Connection Power Cable	Black to orange quick connector, rated current: 125A		Depends on rated capacity (capacity/5.12-1)
3	Total Positive Power Cable	Dual-head black quick connector, rated current: 125A		1

6.5 Communication Cable Connection



Male and female connectors must be inserted into corresponding slots

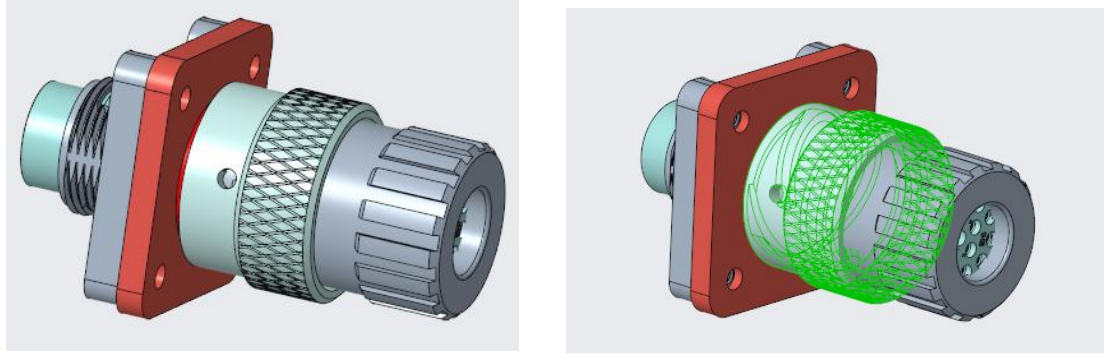

After proper insertion, rotate the connector housing clockwise to lock the connector in the socket.

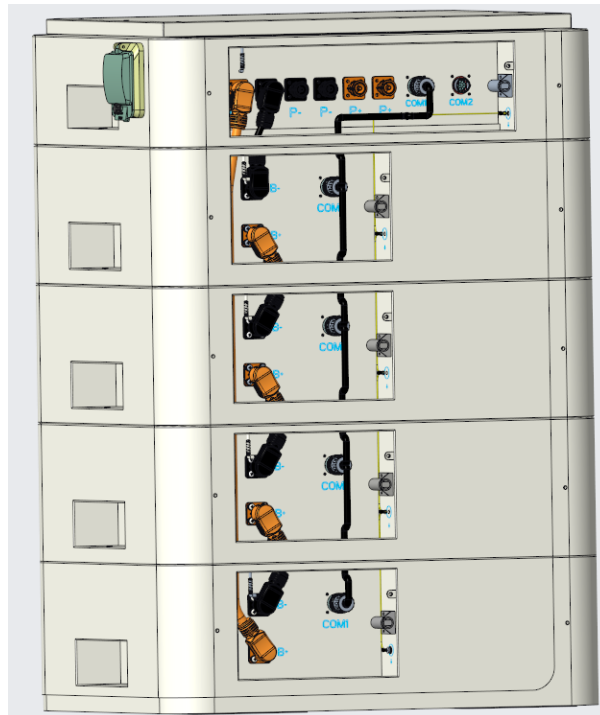

Installation sequence: PACK-2→Upper layer PACK-1.... Finally connect the high-voltage box JSDD-100A (all socket holes are COM1)

No.	Name	Specification	Illustration	Quantity
1	Communication Connection Cable	12PIN communication cable (specific communication connector quantity depends on capacity)		1

6.6 Rear Cover Installation for Electrical Connections



After electrical wiring is complete, close the module rear

7. Startup and Shutdown Operating Procedure

7.1 PRE-STARTUP INSPECTION

7.1.1 Check whether all electrical connection cables are damaged and whether connection terminal wires are securely fastened.

7.1.2 Check whether the fixing screws between battery packs are tightened.

7.1.3 Check whether the ground wire of the battery module is securely connected.

7.2 STARTUP OPERATION

7.2.1 Turn on the main power switch

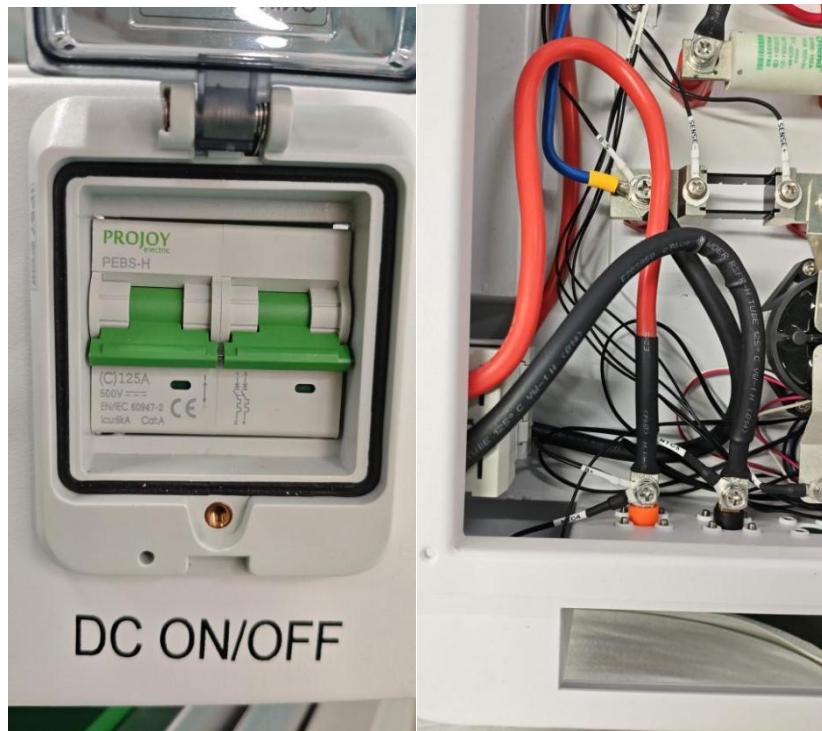

7.2.2 Press and hold the system button switch for 5 seconds then release. The system indicator lights up, and the system enters the self-test program. After approximately 30 seconds, the system self-test is complete and enters normal working mode.

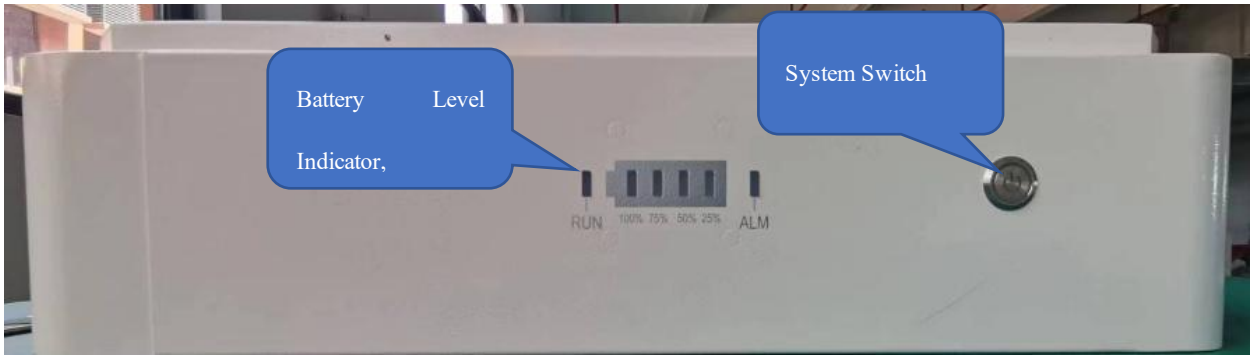

7.2.3 Shutdown Sequence

1. First turn off the system switch and wait until the indicator light switches to standby mode.
2. Then turn off the main power switch.
3. Final shutdown is complete three minutes after all indicator lights are off.
4. When the equipment requires maintenance, it shall also be shut down in accordance with steps 1 - 3.

7.3 USAGE PRECAUTIONS

7.3.1 When equipment malfunctions during use, unauthorized repair and disassembly are prohibited. Contact after-sales technical personnel for handling.

7.3.2 If the battery needs to operate at the maximum continuous current of 75A, after the battery is fully charged or discharged at 75A, it needs to rest for 3 hours before the next 75A discharge or charge. After each round of charge/discharge, the rest time is 20 hours or until the battery system has completely cooled to room temperature before reuse, such as: Charge-Rest 3h-Discharge-Rest 20h-Charge-Rest 3h-Discharge-Rest 20h.

7.3.3 Fuse rated voltage: 500V, current 100A, breaking capacity 6KA.

7.3.4 Circuit breaker rated voltage: 500V, current 100A, breaking capacity 6KA.

7.3.5 Battery product short circuit test current value 2.6kA, time 1.55ms.

7.3.6 Equipment waterproof rating IP54, pollution degree: external 3, internal 2.

7.3.7 Overvoltage category: Battery OVC II; AC grid: OVC III.

7.3.8 When grounding with an inverter is required, refer to clause 6.3, as well as the specifications of the intended inverter.

Maximum PV voltage not exceeding 1000V, AC side 220/230Vac/50Hz, inverter power 10-15KW.

7.3.9 Inverter model parameters are as follows:

	Model	JEEDD-10KWH	JEEDD-12KWH	JEEDD-15KWH
Battery	BatBattery Voltage Range	125~600		

Interface Parameters	(V)			
	Max Battery Current (A)	40		
	Max Charge/Discharge Power (W)	13000	14400	16500
PV Interface Parameters	Max DC Input Voltage (V)	1000		
	MPPT Operating Voltage Range (V)	125~850		
	Startup Voltage (V)	125		
	Max Input Current (A)	13/13A	13/13A	26/26A
	Max DC Input Power (W)	13000	15600	19500
	Max Short Circuit Current*MPPT Channels	16	16	16
	MPPT Input Channels	2	2	2
	MPPT Inputs per Channel	1/1	1/1	2/2
AC Grid- tied Parameters	Rated Output Power (VA)	10000	12000	15000
	Max Output Power (VA)	11000	13200	16500
	Max Input Power (VA)	22000	26400	30000
	Max Output Current (A)	15.8	19	23.8
	Max Input Current (A)	33.4	40	43
	Max Power (W)	10000	12000	15000
	Rated Output Voltage (V)	400V, 3W+N+PE		
	Rated Frequency (Hz)	50Hz/60Hz		
	Current THD (@Rat)	<3%		
	Power Factor	~1 (-0.8~0.8 adjustable)		
AC Off- grid Parameters	Rated Output Power (VA)	10000	12000	15000
	Max Output Power (VA)	11000	13200	16500
	Rated Output Voltage (V)	400V, 3W+N+PE		
	Rated Frequency (Hz)	50Hz/60Hz		
	Current THD (@Rated Power)	<3%		
	Max Efficiency	98.2%	98.2%	98.5%

	European Efficiency	97.5%	97.5%	97.6%
	MPPT Efficiency	99.5%	99.5%	99.5%
	Battery Charge/Discharge Efficiency	97.5%	97.6%	97.8%
Mechanical Parameters	DimensionsH (mm)	602*493*660		
	Weight (kg)	64.5	65.5	70.5
Interface Parameters	Human-Machine Interface	Display or APP (choose one)		
	BMS Interface	CAN		
	Meter Communication Interface	RS485		
	Cloud Communication Interface	WIFI or WAN		
Basic Parameters	Protection Rating	IP20		
	Operating Temperature	-20~55°C		
	Relative Humidity	0~100%		
	Operating Altitude	2000m altitude without derating		
	Cooling Method	Air Cooling		
	Noise	≤25dB		
	Installation Method	Stacking		
Protection Functions	Anti-islanding Protection	Yes		
	PV Input Reverse Polarity Protection	Yes		
	Battery Input Reverse Polarity Protection	Yes		
	Insulation Impedance Detection	Yes		
	Residual Current Detection	Yes		
	PV Input Overvoltage/Overcurrent/Overpower	Yes		
	Battery Input Overvoltage/Overcurrent/Overpower	Yes		
	AC Output/Input	Yes		

	Overvoltage/Overcurrent/Overpower	
	Overttemperature Protection	Yes
	Wave-by-wave Current Limiting	Yes
	Reference Power Supply Fault Protection	Yes

8. Routine Maintenance

8.1 Clean the cabinet as needed. Regularly check whether terminals, cables, contactors, relays, transfer switches, and protectors have dust accumulation. Annually check whether terminals and cables are insulated and secure, test contactor and relay contacts and actions, fuse contact force, whether circuit board jumper cap solder joints are loose, whether components are secure, control functions and state switching of each module are correct, to prevent faults caused by these hidden dangers.

8.2 When performing daily equipment inspections, the direct sensory diagnosis method is generally used for fault diagnosis, which can be summarized as: asking, looking, listening, smelling, touching, and testing.

8.2.1 Look: Observe. Such as observing indicator light colors, human-machine interface displays.

8.2.2 Listen: Listen to sounds. Judge whether normal based on the sound of internal contactors during operation.

8.2.3 Smell: Diagnose based on odors emitted internally.

8.2.4 Touch: Test by hand. Whether there is overheating on the surface, whether there is moisture condensation inside.

8.2.5 Test: Test verification. Such as pressing power button on internal contactors can produce a closing sound

9. Fault Description and Troubleshooting

9.1 Indicator Light Description When Fault Occurs

Protection Fault Status	Indicator LED						Description
	ALM	RUN	L4	L3	L2	L1	
Cell Fault	Steady On	Off	Off	Off	Off	Off	
NTC Fault	Steady On	Off	Off	Off	Off	Steady On	
Pre-charge Fault	Steady On	Off	Off	Off	Steady On	Off	
Short Circuit Fault	Steady On	Off	Off	Off	Steady On	Steady On	
Charge Contactor Fault	Steady On	Off	Off	Steady On	Off	Off	
Discharge Contactor Fault	Steady On	Off	Off	Steady On	Off	Steady On	
Pre-charge Contactor Fault	Steady On	Off	Off	Steady On	Steady On	Off	
Total Negative Contactor	Steady	Off	Off	Steady	Steady	Steady	

Protection Fault Status	Indicator LED						Description
	ALM	RUN	L4	L3	L2	L1	
Fault	On			On	On	On	
Level 3 Charge Cell Overvoltage Protection	Flash 1	Off	Steady On	Off	Off	Off	
Level 3 Charge Total Overvoltage Protection	Flash 1	Off	Steady On	Off	Off	Steady On	
Level 3 Charge Overcurrent Protection	Flash 1	Off	Steady On	Off	Steady On	Off	
Level 3 Discharge Cell Undervoltage Protection	Flash 1	Off	Steady On	Off	Steady On	Steady On	
Level 3 Discharge Total Undervoltage Protection	Flash 1	Off	Steady On	Steady On	Off	Off	
Level 3 Discharge Overcurrent Protection	Flash 1	Off	Steady On	Steady On	Off	Steady On	
Level 3 Charge High/Low Temperature Protection	Flash 1	Off	Steady On	Steady On	Steady On	Off	
Level 3 Discharge High/Low Temperature Protection	Flash 1	Off	Steady On	Steady On	Steady On	Steady On	
System Lock	Flash 1	Flash 1	Flash 1	Flash 1	Flash 1	Flash 1	

9.2 Capacity Indicator Description When No Fault

Capacity Indicator Light		L4	L3	L2	L1
Battery Level (%)	0~25%	Off	Off	Off	Steady On
	25~50%	Off	Off	Steady On	Steady On
	50~75%	Off	Steady On	Steady On	Steady On
	75~100%	Steady On	Steady On	Steady On	Steady On